



A5 Sportback





The Audi A5 Sportback.

The Audi A5 Sportback is in its most progressive form and functionality. With its sharpened design, refined suspension, powerful engines and innovative assistance systems, it is turning progress into a whole new experience.



The image shows the interior of an Audi A5 Sportback. The steering wheel is a three-spoke design with the Audi logo in the center. The dashboard features a digital instrument cluster with a tachometer on the left, a central display showing 'Fahrerassistenz' (driver assistance) information, and a speedometer on the right. The center console has a large infotainment screen displaying navigation and other functions. Below the screen is a climate control panel with two digital temperature displays (21.0 and 22.0) and various control buttons. The gear shifter is located in the center console, and the handbrake is visible on the right side. The interior is finished with dark wood trim and red leather seats.

**Where innovations
take shape: the interior.**

Turn your ideas into reality in the interior of the new A5 Sportback. From the seats, leather steering wheel in 3-spoke design with multifunction plus to the inlays. Every detail is made from high-quality materials and has a captivating first-class finish. For a unique look that is bound to turn heads.



Perpetual progress: with the Audi virtual cockpit. The digital instrument cluster is versatile and innovative. The large 12.3-inch LCD screen presents everything in razor-sharp definition. From navigation, telephone to music.

Top marks for progressiveness. Impressive all along the line.

The curved side lines and the powerful wheel arches create the perfect setting for the Audi sport cast alloy wheels and lend expression to the quattro all-wheel drive. The flowing silhouette and crisp lines express an elegant sportiness and hint at the power of the engine concealed beneath the bonnet. With a higher power output, lower fuel emissions and the TFSI engine, the Audi A5 Sportback exceeds expectations when it comes to driving performance.



Solid paint finishes

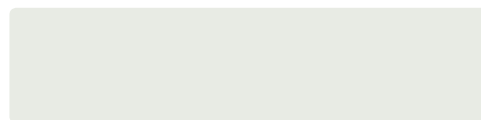

Ibis white



Brilliant black

Metallic paint finishes

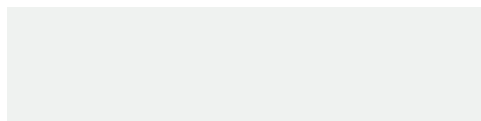

Glacier white, metallic

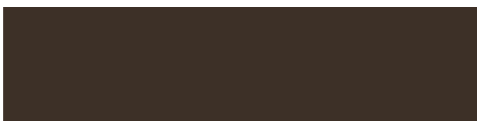

Argus brown, metallic



Tango red, metallic



Mythos black, metallic



Navarra blue, metallic



Floret silver, metallic



Monsoon grey, metallic



Matador red, metallic



Manhattan grey, metallic

Audi A5 Sportback

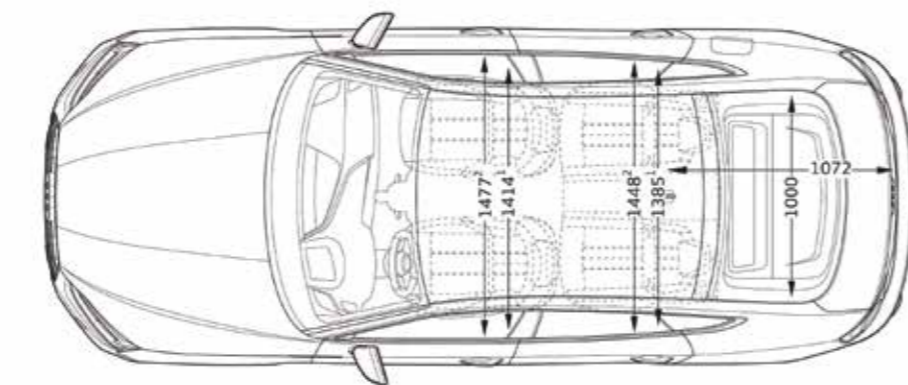
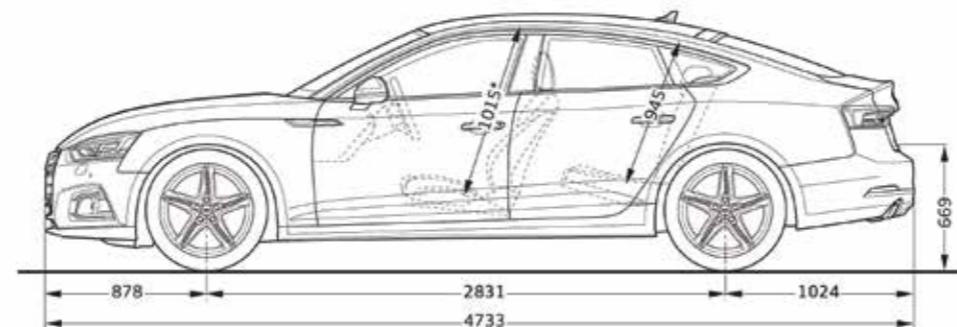
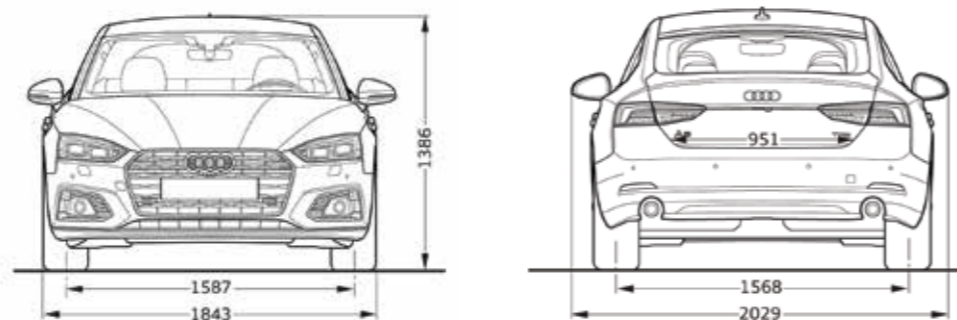

Dimensions in millimetres.
 Dimensions measured with vehicle at unladen weight.
 Luggage compartment volume in litres: 480/- (2nd value: with rear seat bench folded)
 (measured by the VDA method using 200 x 100 x 50 mm blocks).
 Turning circle approx. 11.5 m.
 * Maximum headroom. ¹Elbow room width. ²Shoulder room width.

Model

Engine type

Displacement in cc (valves per cylinder)

Max. output in kW(hp) at rpm

Max. torque in Nm at rpm

Power Transmission

Drive type

Transmission type

Weights/capacities

Kerb weight in kg

Gross vehicle weight

Permissible roof load limit

Fuel tank capacity

Performance/consumption

Top speed in km/h

Acceleration 0-100 km/h in s

Fuel grade

Fuel consumption (combined) in l/100km

CO₂ emissions in g/km combined

Emission standard

Audi A5 Sportback sport 2.0 TFSI quattro S tronic

4-cylinder inline spark-ignition engine with gasoline direct injection, exhaust turbocharger and Audi valvelift system

1,984 (4)

185 (252) / 5,000 - 6,000

370 / 1,600 - 4,500

quattro permanent all-wheel drive

7-speed S tronic transmission

1,535

2,105

75

58

250

6.0

Sulphur-free super unleaded RON 98

6.4

146

EU6



Audi Sport cast alloy wheels, 10-V-spoke style, 8.5J x 19 with 255/35 R 19 tyres.

Audi Malaysia

A business division of Volkswagen Group Malaysia (“VGM”)

www.audi.com.my

Printed April 2019

The models and equipment versions illustrated and described in this brochure and some of the services listed are not available in all countries. Some of the cars illustrated are equipped with optional features for which an extra charge is made. Details concerning the delivery specifications, appearance, performance, dimensions and weights, fuel consumption and running costs of the vehicle were correct to the best of our knowledge at the time of going to press. Deviations from the colours and shapes shown in the illustrations may occur. No liability is accepted for errors and printing errors.

